

Robust valve control device giving a confidence in reliable performance and outstanding durability under harsh working environments



Ex ATEX-approved (flameproof)



Intrinsically safe / Non-explosion proof



With Dome Indicator

Specifications

	EPR	
	Rotary Type (Cam Feedback)	
	Single	Double
Input Signal	4~20 mA DC (Note. 1)	
Input Resistance	235 ± 15 Ω	
Air Supply	Max. 7.0 bar (100 psi) free of oil, water, and moisture	
Operating Angle	60 ~ 100° (Note. 2)	
Pneumatic Connections	Rc 1/4 or NPT 1/4	
Electrical Connections	G 1/2 or NPT 1/2	
Protection Class	Ex md IIB T6, Ex md IIC(H ₂) T6, IP66, Ex ia IIB T6 Eex md IIB T5 for ATEX Ex	
Ambient Temperature	-20 ~ +70 °C	
Pressure Gauge	Stainless steel	
Output Characteristics	Linear	
Linearity	Within ±1.0 % F.S	Within ±1.5 % F.S
Sensitivity	Within ±0.5 % F.S	
Hysteresis	Within 1.0 % F.S	
Repeatability	Within ±0.5 % F.S	
Air Consumption	5 LPM (Sup. 1.4 kgf/cm ²)	
Flow Capacity	80 LPM (Sup. 1.4 kgf/cm ²)	
Material	Aluminum die-cast	
Weight	3.5 kg (with terminal box) 3.2 kg (without terminal box)	

Note : 1) 1/2 split range is available for 4-12mA input signal or 12-20mA input signal
2) Operating angle can be adjusted to 0~60° or 0~100°

Features

- ▶ Easy maintenance
- ▶ Precise calibration with simple SPAN and ZERO adjustments
- ▶ Simple conversion to direct acting or reverse acting
- ▶ 1/2 split range available
- ▶ Rugged aluminum housing with corrosion-resistant coating
- ▶ Vibration resistant design
- ▶ Stainless steel gauges standard
- ▶ Restricted pilot valve orifice kit for small actuators included
- ▶ Certified for ATEX **Ex** Eex md IIB T5 (05 ATEX 1076X) by NEMKO in conformance with EN 50014:1997, EN 50018:2000 and EN 50028:1987
- ▶ Certified for EMC (K1046 / E04) in conformance with EN 61000-6-2:2001 and EN 61000-6-4:2001 by RWTUV
- ▶ Certified for Ex md IIB T6 (99-1075-Q1), Ex md IIC T6 (2000-1057-Q1), and Ex ia IIB T6 (2000-1056-Q1) by KOSHA

Options

- ▶ Position transmitter (4...20 mA output signal)
- ▶ 2 x SPDT limit switch
- ▶ 2 x P&F proximity sensor NJ2 - V3 - N
- ▶ Visual dome indicator
- ▶ High temperature

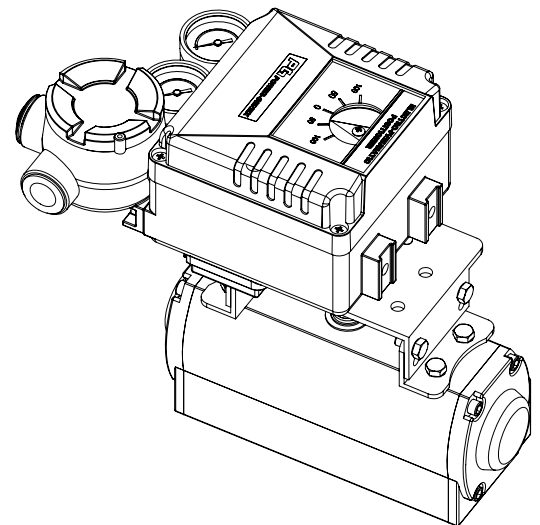

Mounting

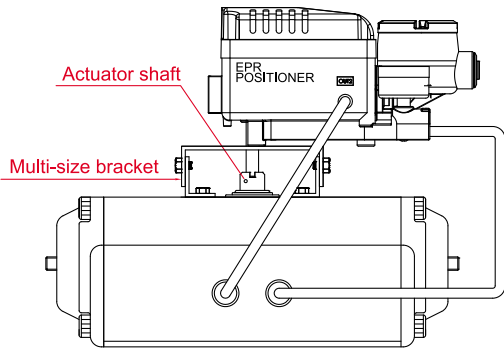

NAMUR Type Mounting

Note that feedback lever shaft "A" should be placed in the orifice of fork lever "B" and they should be in perfect alignment with a rotary actuator output shaft

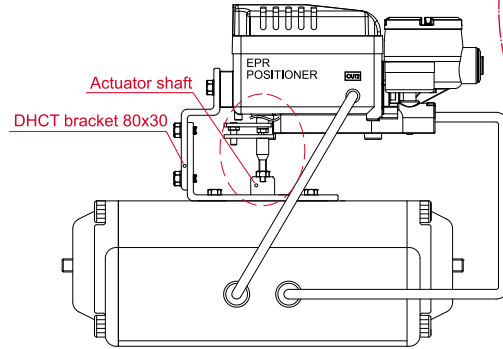

Fork Lever Type Mounting

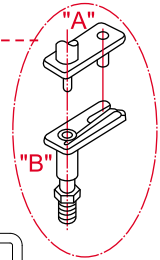

Internal View

Auto/Manual screw
Stopper screw
Seat adjuster

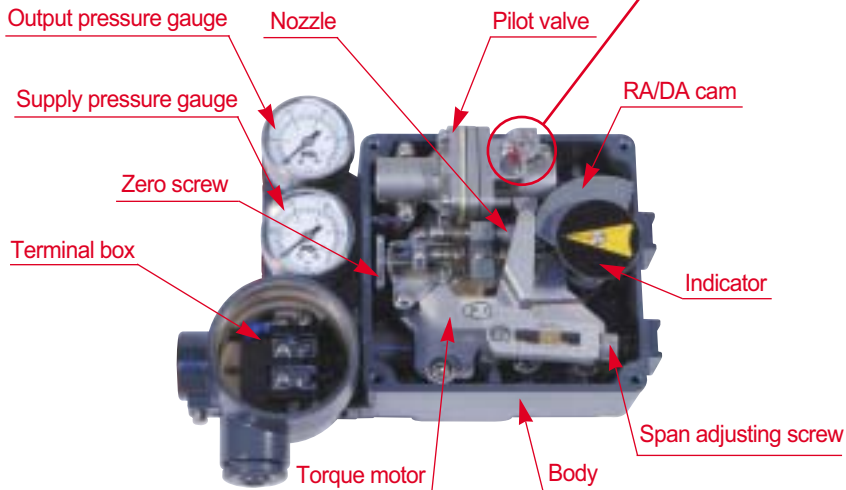
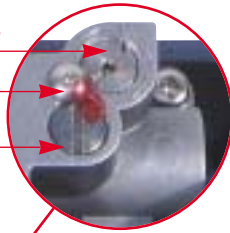

Multi-size Bracket

TYPE	H
80 x 30 x 20H	41
80 x 30 x 30H	51
130 x 30 x 20H	41
130 x 30 x 30H	51
130 x 30 x 50H	71

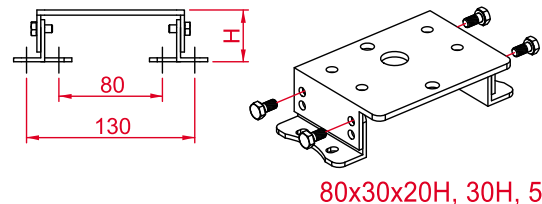
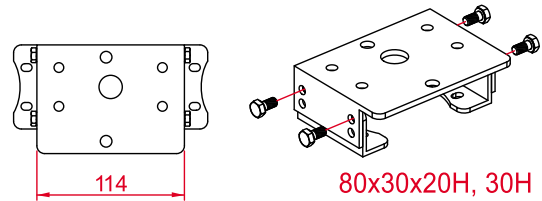

Air Connections

Direct Acting (DA)

As the input signal increases, Actuator stem rotates clockwise.

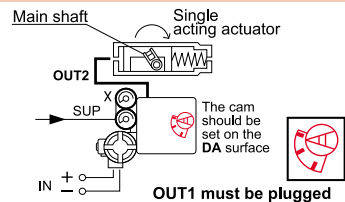

As the input signal increases, Actuator stem rotates clockwise.

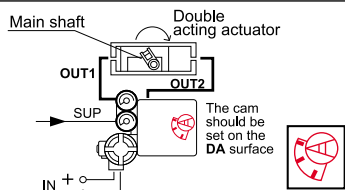

Reverse Acting (RA)

As the input signal increases, Actuator stem rotates counter clockwise.

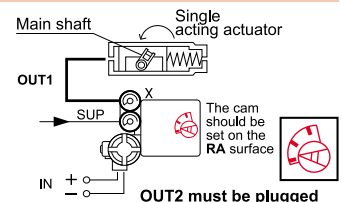

As the input signal increases, Actuator stem rotates counter clockwise.

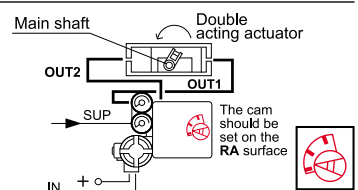

Position Transmitter Options (Built-in Type)

1. Board View

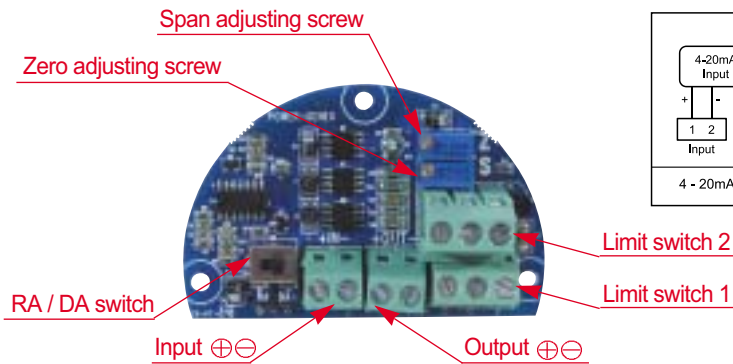

2. Wiring Diagram

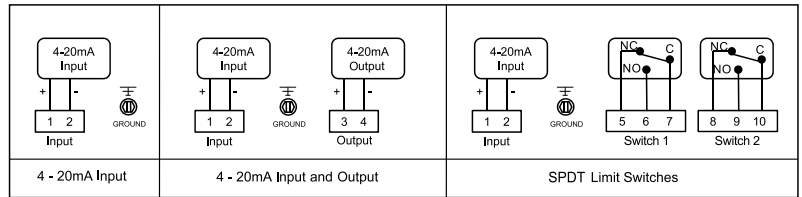

3. Position Transmitter (4-20mA output signal)

a. Specifications

Power Supply Rating	5.5-30 VDC loop power
Recommended Power Supply	24 VDC
Output Signal	4 - 20 mA, 2-wire
Operating Temperature	-20° to 70 °C
Load Impedance	0 ~ 600 ohms
Max. Output	30 mA DC
Linearity	±1.0 %
Hysteresis	1.0 % of full scale
Repeatability	±0.5 % of full scale
Adjustment	Zero and Span in terminal box

b. with mA calibrator

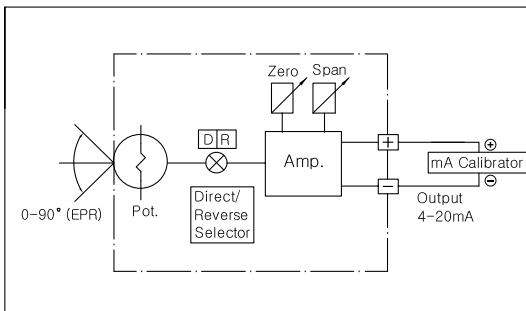

c. with multimeter

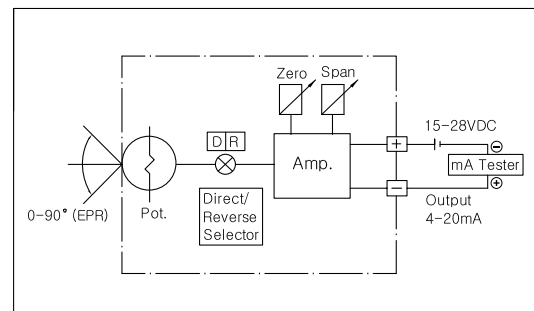

4. SPDT Limit Switches

a. Specifications

Contacts	SPDT Form C
AC Rating	16 A 1/2 HP 125/250 VAC
DC Rating	0.6 A 125 VDC / 0.3 A 250 VDC
Adjustment	Cams with set screws (L-wrench included for setting)

b. Wiring and Application

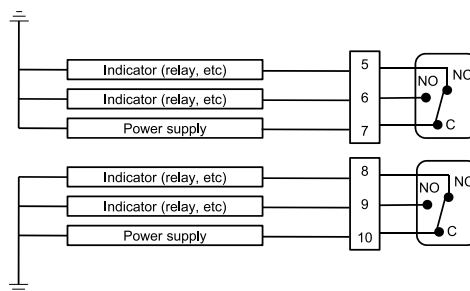

How to Order

EPR

Protection Class	Feedback Shaft	Pressure Gauge (SUP. OUT)	Pilot Valve Orifice	Position Feedback	Connection Threads	Dome Indicator	High Temp	Mounting Bracket
------------------	----------------	---------------------------	---------------------	-------------------	--------------------	----------------	-----------	------------------

Description	Code
Protection Class:	F : Flameproof Ex md IIB T6 D : Flameproof Ex md IIC T6 A : Flameproof Eex md IIB T5 ATEX  I : Intrinsic safety (Ex ia IIB T6) W : Weatherproof to IP66
Feedback Shaft:	N : NAMUR shaft (direct mounting) A : Fork lever M6 x 40L B : Fork lever other size on request
Pressure Gauge:	1 : 6 bar (90 psi) 2 : 10 bar (150 psi, standard)
Pilot Valve Orifice:	S : Standard (Actuator volume over 180 cm ³) M : Small orifice (φ1.0 or φ0.7) (Actuator volume 90~180 cm ³)
Position Feedback: (only for weatherproof type)	N : None (standard) O : Position transmitter (4~20mA output signal) L : 2 x SPDT limit switch P : 2 x proximity sensor P&F NJ2-V3-N M : O + L Q : O + P

Description	Code
Connection Threads: (pneumatic - electrical)	3 : Rc 1/4 - G 1/2 (standard) 4 : NPT 1/4 - NPT 1/2 5 : Rc 1/4 - M20 x 1.5
Dome Indicator:	N : Flat indicator (standard) D : Dome indicator
High Temperature: (only for weatherproof type)	T : 70 °C (standard) H : 120 °C (without position feedback option) 85 °C (with position feedback option)
Mounting Bracket:	N : None
- NAMUR Shaft Type :	R : Multi-size NAMUR bracket for DIN VDI/VDE 3845 (130 × 30 × 50 bracket on request)
- Fork Lever Type :	F : DHCT bracket 80x30 for fork lever type E : Multi-size NAMUR bracket for fork lever type (130 × 30 × 50 bracket on request)

Dimensions

A. With Flat Indicator

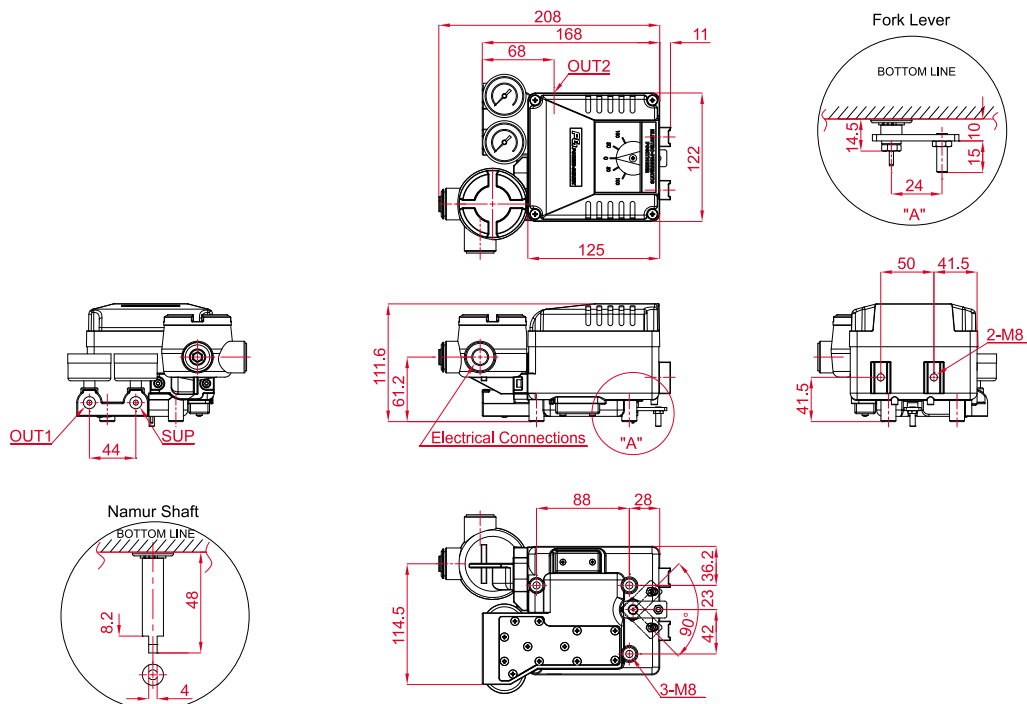

B. With Dome Indicator

